

CUSTOMER'S NAME:	
CUSTOMER'S P.O. NO.:	
REOTEMP ORDER NO.:	
CERTIFIED BY:	DATE:

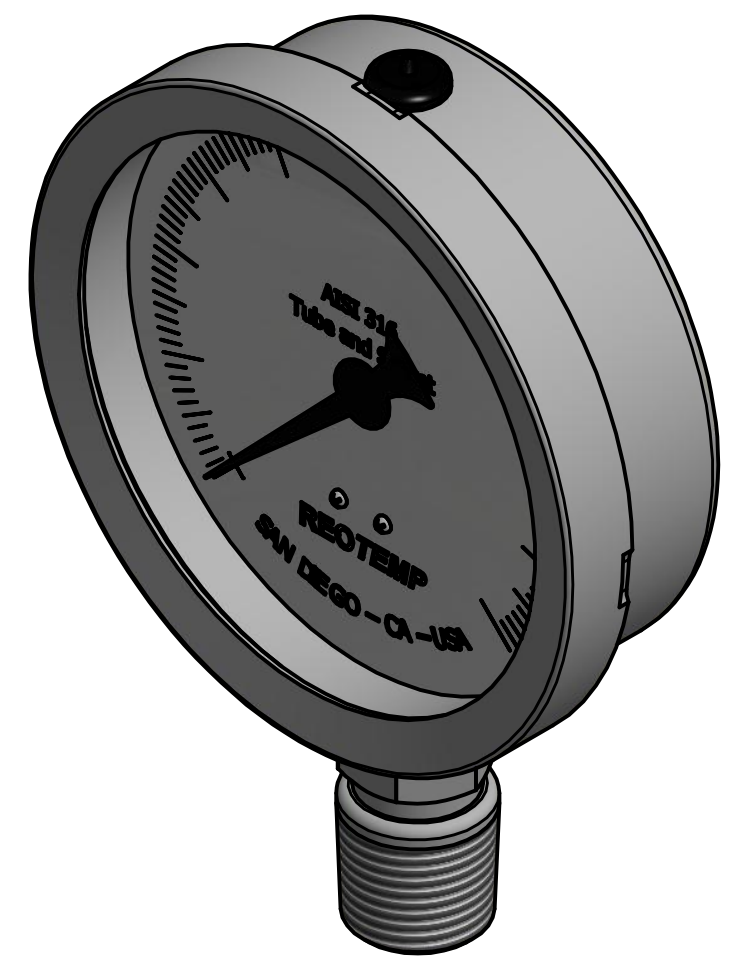
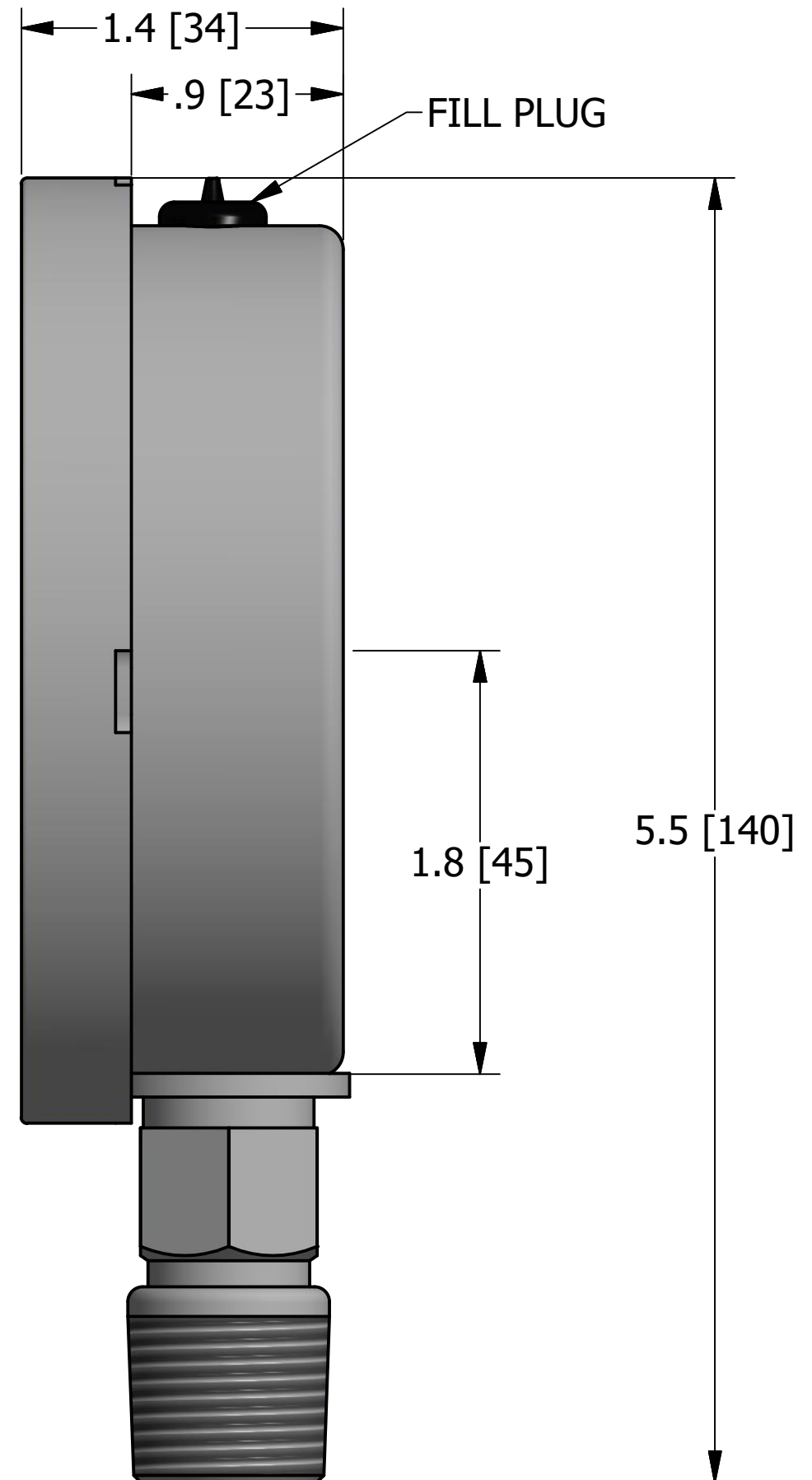
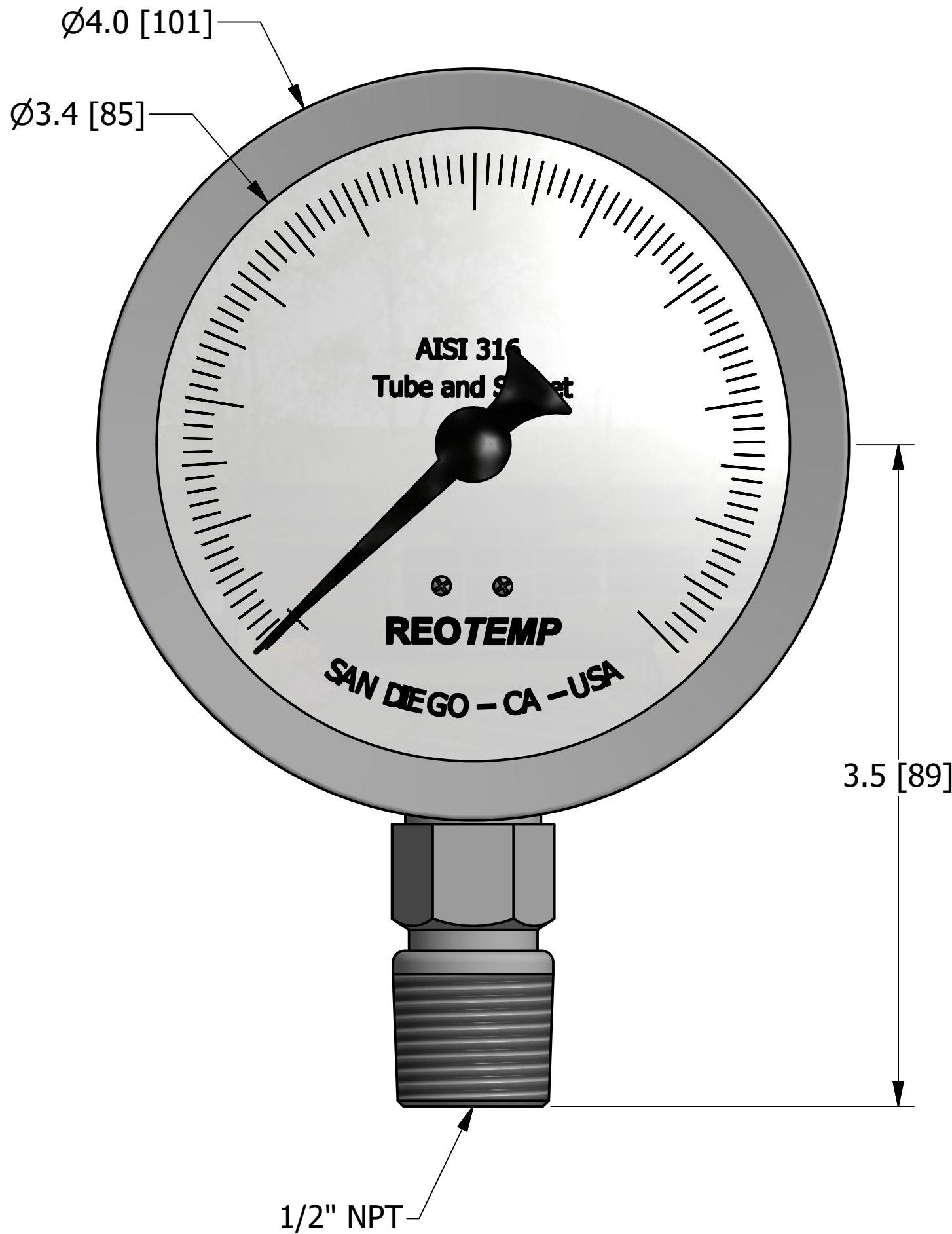

REVISIONS			
REV	DESCRIPTION	DATE	APPROVED
X1	INITIAL RELEASE	12/11/15	

CASE MATERIAL: 304SS		UNLESS OTHERWISE SPECIFIED DIMENSIONS ARE IN INCHES & [mm] TOLERANCES ARE: FRACTIONS    DECIMALS    ANGLES ±1/32        .X ± .2        ±5° .XX ± .01 .XXX ± .005 SURFACE FINISH    63√		PART NAME:		DATE: 12/11/15	
WETTED MATERIAL: 316LSS				PR35 1/2" NPT BOTTOM CONNECT		DRAWN BY: MNeill	
POINTER: MICRO-ADJUSTABLE						APPROVED:	
ENCLOSURE RATING: IP67/NEMA 4X		PART NO: PR35S1A2		SIZE: C	CAGE CODE: 24793	DWG NO: 40039	
		FIRST USED ON:		SCALE: NTS		FILE NAME:	
						SHEET 1 OF 1	